

# LITE

THE HOERBIGER DIRECT CLASS

The HOERBIGER Direct Class for the first time provides the option to order HOERBIGER quality quickly, easily and directly — worldwide, around the clock, and at a remarkable price-performance ratio. HOERBIGER Lite is fast, simple, and always on the cutting edge.

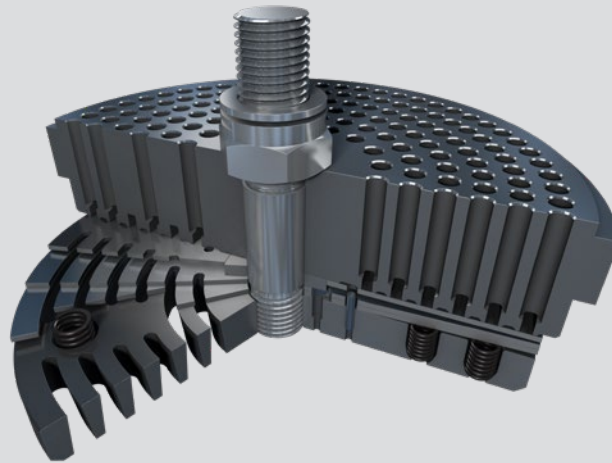

## HDS valve

The classical plate type valve in for process gas applications

- The valve is the heart of the compressor **directly affecting the compressor performance** and operation.
- The HDS valve is a double-damped plate type valve addressing high pressure standard applications and thus the ideal solution for cost-conscious customers looking for **genuine HOERBIGER products at the best available price.**
- The HDS valve is available with either **steel valve plate or non-metallic valve plate** for lubricated and non-lubricated service.
- The **proven design** of this valve type is refined to provide good efficiency at low lifts .
- **Worldwide proven reliability** and durability in numerous process gas applications since 1972.
- Price-competitive plate type valve with **HOERBIGER quality and performance.**
- **Proven HOERBIGER quality** in high precision manufacturing and **100% testing** ensures stringent sealing requirements and trouble free compressor operation.

**YOUR  
EASY  
WAY**

  
**HOERBIGER**  
*because performance counts*

## HDS Ventil

The HDS valve offers proven HOERBIGER valve technology at best available price with a standard product configuration. The HDS valve is a highly standardized product with competitive delivery time for new build and spare parts orders.



### Prozessgas | Erdgas

Compressor speed :	1200 rpm maximum
Capacity control:	On/Off
Lubrication:	lubricated, non-lubricated
Maximum pressure:	300 bar
Pressure differential:	100 bar*
Temperature range:	-160° to +300°C*
Valve type diameter:	92–254 mm

### Suitable Industries

- Petrochemical & Chemical Industry
- Technical Gases
- Natural Gas

### Suitable applications

- Urea Production
- Oxygen
- LNG Boil Off Gas

### Post Sales Support

- 1 year warranty
- Back to factory support

\*Depending on valve plate material.

[www.hoerbiger.com](http://www.hoerbiger.com)

HOERBIGER is active throughout the world as a leading player in the fields of compression technology, drive technology and hydraulics. In 2017, its 7,300 employees achieved sales of 1.173 billion euros. The HOERBIGER brand is synonymous with components and services providing high customer value in compressors, industrial engines and turbines, automotive drivetrains, and multifaceted mechanical engineering applications. HOERBIGER industrial safety and explosion mitigation solutions save lives and equipment. We set standards.

© HOERBIGER 2018